

UNIDIRECTIONAL DYNAMIC MICROPHONES

General: The Model 581 Series Unidyne A Microphones are moving coil dynamic units built to provide excellent reproduction of music and voice and to feature an exceptionally good unidirectional microphone pickup pattern.

These microphones are particularly suitable for use in theatres, night clubs, auditoriums, schools, churches, and any place where ordinary microphones may not operate properly because of poor acoustics. These microphones will in almost every instance eliminate the annoying "squeals and howls" caused by feedback. In addition, they will prevent echoing (boominess) that sometimes occurs in partially-filled halls. These microphones can also be used closer to loudspeakers than usual, without creating feedback problems.

This suppression of feedback, combined with their smooth sound, makes them particularly good for use with orchestras, small combos, and singers.

In addition, the microphone features:

- A strong, easily disconnected cable, especially selected because of its good shielding from "hum pickup".
- An easily field-replaceable microphone cartridge.
- A cartridge that is protectively shock-mounted internally, which permits quieter handling.
- A built-in "on-off" switch with a device to lock the switch in its "on" position.
- An adjustable swivel adapter that enables you to aim the microphone where you want it.
- A plastic cushioned slot in the swivel that makes it easy to quietly pull the microphone out and use it comfortably in the hand.

The Model 581SA is high impedance for connection into high impedance microphone inputs.

The Model 581SB has a low impedance of 150 ohms and is recommended where long cable lengths are required, or where there are conditions of severe hum disturbance. To use the Model 581SB with a high impedance amplifier, use a Shure Model A95A Line Matching Transformer.

The Model 581SF has a low impedance of 25 ohms and is designed for installations where lower impedances are required.

The Model 581SA-MP is a set of two matched Unidyne A Unidirectional Dynamic Microphones. The units are matched within 1.0 db in level and within 1.5 db for frequency response.

For convenient connection to most tape recorders, standard phone plugs have been installed on the Model 581SA-MP microphone cables. All features, specifications, and performance data listed for the Model 581SA apply to the Model 581SA-MP Microphones.



Models 581SB and 581SF

Model 581SA

The matched Model 581SA Microphones are primarily intended for stereo recording or similar use. Many acoustic conditions affect the final placement of microphones during a stereo recording. It is usually necessary to experiment with various locations of the microphones to achieve placement best suited to your individual requirements. For pickup of large groups, it may be advisable to raise the microphones above the performers to gain balance between front and rear of the group.

SPECIFICATIONS

Type: Dynamic

Frequency Response: 50 to 12,000 Hz (cps)

Polar Pattern: Cardioid (unidirectional) Response. Uniform with frequency, symmetrical about axis (See Figure B)

Microphone Rating Impedance:

Model 581SA High Impedance
Model 581SB 150 ohms

For connecting into microphone inputs rated at 50 to 200 ohms

Model 581SF 25 ohms

For connection into microphone inputs rated at 25 to 50 ohms

Output Level: 1000 Hz (cps) Response

Model 581SA High Impedance

Open circuit voltage— 56.5 db (1.48 mv)

EIA Microphone Rating

G_m (Sensitivity)—152.5 db***

Model 581SB 150 ohms Impedance

Open circuit voltage— 79.5 db* (.105 mv)

Power Level— 57.0 db**

EIA Microphone Rating

G_m (Sensitivity)—151.0 db***

Model 581SF 25 ohms Impedance
 Open circuit voltage— 87.5 db* (.043 mv)
 Power Level— 57.0 db**
 EIA Microphone Rating
 Gm (Sensitivity)—152.5 db***

* 0 db = 1 volt per microbar
 ** 0 db = 1 milliwatt with 10 microbars
 *** 0 db = EIA Standard SE-105, August 1949.

Switch: Built-in "ON-OFF" switch with lockplate furnished. Microphone is shipped with lockplate installed. To lock switch in "ON" position, loosen screw on lockplate and turn lockplate 180°. Retighten screw.

Shock Mount: Internal vibration-isolation of rubber construction.

Case: Die-cast and "Armo-Dur".

Case Finish: Chrome and Gray with stainless steel grille.

Dimensions: See Figure A.

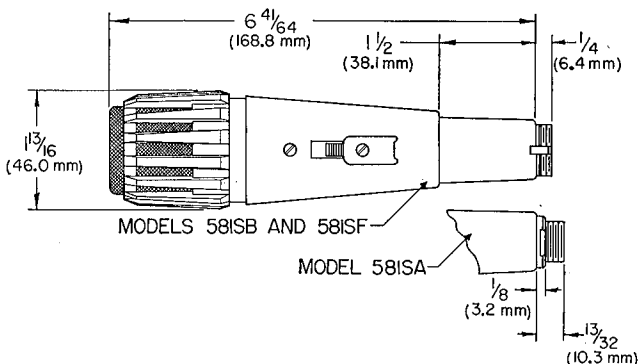

OVERALL DIMENSIONS
 FIGURE A

Net Weight: 13 oz. (369 gms)

FURNISHED ACCESSORIES:

Cable: Highly durable with exceptionally effective hum shielding.

Model 581SA

Detachable 15 foot (4.6 meter) one-conductor shielded cable with microphone connector.

Model 581SA-MP

Detachable 15-foot (4.6 meter) one-conductor shielded cable with microphone connector and a standard phone plug attached.

Model 581SF and 581SB

Detachable 18-foot (5.5 meter) two-conductor shielded cable with microphone connector attached.

Swivel Adapter: Model A25B, long life, high quality swivel connector, lined with a long-life nylon sleeve for noise free and scratch-free insertion and removal of microphone.

Guarantee: This Shure product is guaranteed in normal use to be free from electrical and mechanical defects for a period of one year from the date of purchase. Please retain proof of purchase date. This guarantee includes all parts and labor.

Shipping Instructions: Carefully repack the unit and return it prepaid to the factory. If outside the United States, return the unit to your dealer or Authorized Shure Service Center for repair. The unit will be returned to you prepaid.

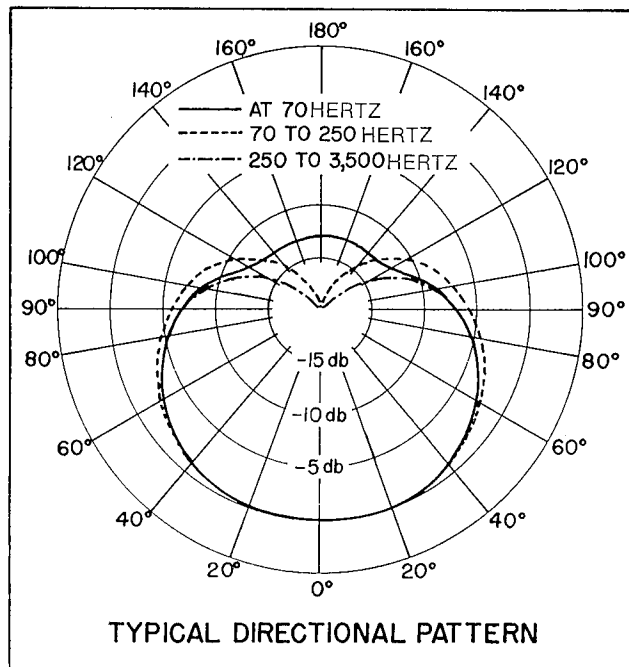

FIGURE B

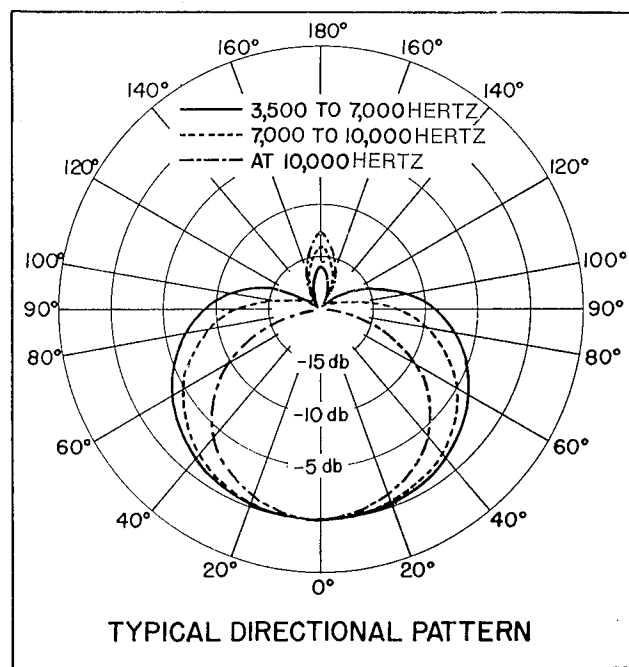

FIGURE B

Replacement Components Installation and Connections:

Model R58 Dynamic Replacement CARTRIDGE
for Models 581SA and 581SB

Model R58F Dynamic Replacement CARTRIDGE
for Model 581SF

Model 94A344 Replacement SWITCH

A. To install the R58 Cartridge in Shure Models 581SA or 581SB, and the R58F CARTRIDGE in the Shure Model 581SF, proceed as follows:

1. Holding microphone in vertical position with head upper most, unscrew (turn counterclockwise) and remove the microphone cap-grille assembly and the metal washer. See Figure C.
2. Gently remove cartridge from the case.
3. Unsolder the leads from old cartridge terminals.
4. Connect the leads to the new replacement cartridge. Note the lead color and terminal coding as in Figure D-1 and D-2.
5. Assemble cartridge into case making sure it is properly seated in the notches provided. This prevents the cartridge from turning when cap-grille assembly is screwed on.
6. Re-assemble metal washer and cap-grille assembly. Make sure the cap is tightened securely.

B. To install the 94A344 Replacement Switch in the Shure Models 581SA, 581SB, and 581SF, proceed as follows:

1. Remove cartridge as in Section "A" but do not disconnect the leads from the cartridge.
2. Remove "lamb's wool" packing from inside microphone case. Long nose pliers or tweezers may be used for this.
3. Remove the two #4-40 oval head machine screws, located at both ends of the switch button.
4. Reach in with long nose pliers or tweezers and pull out the switch (if a Model 581SB or 581SF) or the switch-transformer assembly (if a Model 581SA).
5. Disconnect the leads from the old switch terminals and remove old switch from the plastic transformer bracket (if a Model 581SA).

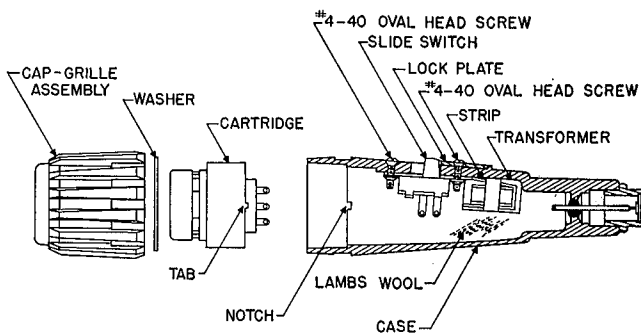

EXPLODED VIEW OF MODEL 581SA MICROPHONE
FIGURE C

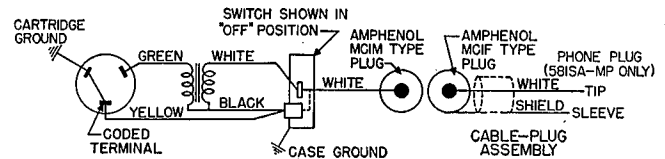

MODEL 581SA INTERNAL CONNECTIONS
FIGURE D-1

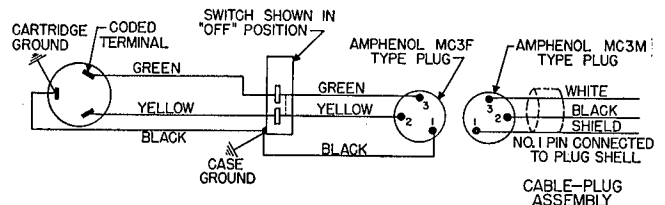

MODEL 581SB AND 581SF INTERNAL CONNECTIONS
FIGURE D-2

6. Connect the leads to the new replacement switch. Observe lead color and terminal arrangement as in Figure D-1 and D2.

NOTE: When the 94A344 replacement switch is installed in the Model 581SA, the sponge rubber gasket on the switch must be removed.

7. Re-assemble switch or switch-transformer combination back into the case and fasten securely with the two #4-40 oval head screws. The longer screw is used at the bottom (toward cable) end of the switch.
8. Replace the "lamb's wool" packing. Tight packing is necessary around the transformer but loose packing is required above the transformer.
9. Re-assemble cartridge into case and replace cap-grille assembly as in Section "A"—steps 5 and 6.

